

RESEARCH ARTICLE

Online Heart-Cutting Liquid Chromatographic Analysis of Linezolid in Human Serum

Olcay Sagirli*, Seda Demirci and Armağan Önal

Faculty of Pharmacy, Department of Analytical Chemistry, Istanbul University, Istanbul, Turkey

Abstract: In this assay, a selective, simplistic and sensitive new online heart-cutting Liquid Chromatographic analysis method was developed for the quantification of linezolid in human serum. The new method allows to the quantification of linezolid in serum without complicated sample preparation. Before analysis, the samples were mixed with methanol and filtered. Separations were carried out with following systems; 1st dimension is a system consisting of 2.1 x 50 mm Biphenyl pre-separation column with acetonitrile and 0.03 M o-phosphoric acid solution mixture (15:85) as mobile phase and the 2nd dimension is a system consisting of 4.6 x 150 mm Pentafluorophenyl propyl separating column with acetonitrile and 0.03 M o-phosphoric acid solution mixture (25:75) as mobile phase. Two systems were connected via a 6-port valve having 0.2 mL loop and separations were carried out continuously during injections. For both systems, 250 nm has been selected as detection wavelength. The concentration range of 0.5-20 µg/mL was found as linear calibration curve. The new method was successfully applied for the quantification of linezolid in human serum samples collected from a volunteer who has received 600 mg linezolid orally.

ARTICLE HISTORY

Received: April 30, 2016
Revised: May 28, 2016
Accepted: May 29, 2016

DOI:
10.2174/15734129126661607261635
10

Keywords: Linezolid, Online Heart-Cutting Liquid Chromatography, UV Detection, Human Serum, Method Development & Validation.

1. INTRODUCTION

Linezolid, (S)-N-[[3-[3-Fluoro-4-(4-morpholinyl)phenyl]-2-oxo-5-oxazolidinyl] methyl]-acetamide (Fig. (1)) is a synthetic antibacterial agent of the oxazolidinone class which active against most Gram-positive bacteria that cause disease, including streptococci, vancomycin-resistant enterococci (VRE), and methicillin-resistant *Staphylococcus aureus* (MRSA) [1]. Linezolid is rapidly and extensively absorbed after oral administration. Maximum plasma linezolid concentrations are usually achieved between 1 and 2 hours after oral administration [2].

Liquid chromatographic methods involving different sample preparation technique, i.e. protein precipitation [3-9], liquid-liquid extraction [10, 11], solid-phase extraction [12, 13], microdialysis [5] and Dried Blood Sample [14] were performed for linezolid analyzing in biological samples. In this study, a new heart-cutting liquid chromatographic (LC) method was presented without any extraction technique in serum samples by ultraviolet (UV) detection. Online heart-cutting methods has some advantage over other separation methods like comprehensive separation, excellent resolution and minimize the sample losses [15-18].

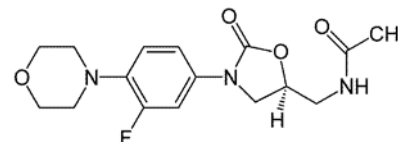

Fig. (1). Chemical structure of Linezolid.

The purpose of the current study is to develop a selective, simplistic and sensitive online heart-cutting LC method with UV detection for the quantification of linezolid in human serum samples. The proposed method was also successfully applied to the quantification of linezolid in serum samples collected from a volunteer who has received 600 mg linezolid orally.

2. EXPERIMENT

2.1. Chemicals and Solutions

Linezolid and its formulation (Zyvoxid Film Tablet® 600 mg of linezolid) were supplied from Pfizer İlaçları Limited Şti. (Istanbul, Turkey). Ultrapure water was obtained from water purification system (ELGA Purelab Option-Q DV 25 (UK)) and the chemicals and solvents were of gradient and analytical grade.

The 0.5 mg/mL concentration of linezolid was prepared in water (Stock solution 1). The concentrations of 2.5, 5, 15,

*Address correspondence to this author at the Department of Analytical Chemistry, Faculty of Pharmacy, Istanbul University, 34116, Istanbul – Turkey; Tel: +902124400000-13587; Fax: +902124400252; E-mail: olcaysagirli@yahoo.com

25, 50 and 100 $\mu\text{g/mL}$ of linezolid solutions for spiked serum study were prepared by diluting the first stock solution with same solvent (Stock solutions 2). The standard solutions of linezolid were prepared at different concentrations (0.5, 1, 3, 5, 10 and 20 $\mu\text{g/mL}$) diluted with water from second stock solutions.

2.2. Chromatographic System

The separations were carried out using a Shimadzu LC-20A chromatography system (Kyoto, Japan). First chromatographic system was consisted of a pump (LC-20AT), a vacuum degasser (DGU-20A5), an autosampler (SIL-20AC), a column oven (CTO-20A), a 6-port valve (FCV-12AH, having a 0.2 mL steel loop) and a UV detector (SPD-20A). Second chromatographic system was consisted of a pump (LC-20AD), a vacuum degasser (DGU-20A5), a column oven (CTO-20A, 1st system oven) and a PDA detector (SPD-M20A) and two systems were connected via 6-port valve which controlled by a system software (LC Solution Version 1.24). LC data were collected and processed by the same system software. First chromatographic system is consisting of 2.1 x 50 mm Biphenyl pre-separation column with acetonitrile and 0.03 M o-phosphoric acid solution mixture (15:85) as mobile phase and the 2nd chromatographic system is consisting of 4.6 x 150 mm Pentafluorophenyl propyl separating column with acetonitrile and 0.03 M o-phosphoric acid solution mixture (25:75) as mobile phase. Detection wavelength has been selected as 250 nm for both systems. The scheme of the system for two valve positions described was provided in Fig. (2).

2.3. 2D System Parameters

Some special parameters about 2D-LC system were investigated like “switching time for valve”, “sample volume in loop” and “differentiation on pressure”. At first, time for rotation of the 6-port valve from 0 position to 1 was investigated. Some assays were performed in order to establish the moment where the amount of analyte reached the highest level in the loop. For this purpose, linezolid within the sample loop was sent to the 2nd system by switching the valve from position 0 to 1 at time points 2.0, 2.1, 2.2, 2.3, 2.4 and 2.5 minutes representing the completion of linezolid peak obtained after injection of standard substance in the 1st system. Switching time was selected based on the evaluation of peak areas resulting from the analysis of this analyte.

After the selection of valve rotation time, different sample volumes for loop were tested. Optimum volume of the sample was determined to enable the delivery of the linezolid with matrix in the 1st system mobile phase to the 2nd system. In this assay, theoretically the recovery of the analyte proportionally increased with the increasing volume of the loop. However, increasing volume of the loop led to band broadening in the 2nd system. Based on these findings, volume of the loop should be adjusted to have an appropriate recovery with sharp peaks. In order to find optimum loop volume, loops having different volumes of 0.1, 0.2, 0.5 and 1 mL were set in the 6-port valve where the most suitable volume for sample loop was selected according to analysis results of standards and serum samples in described analytical conditions.

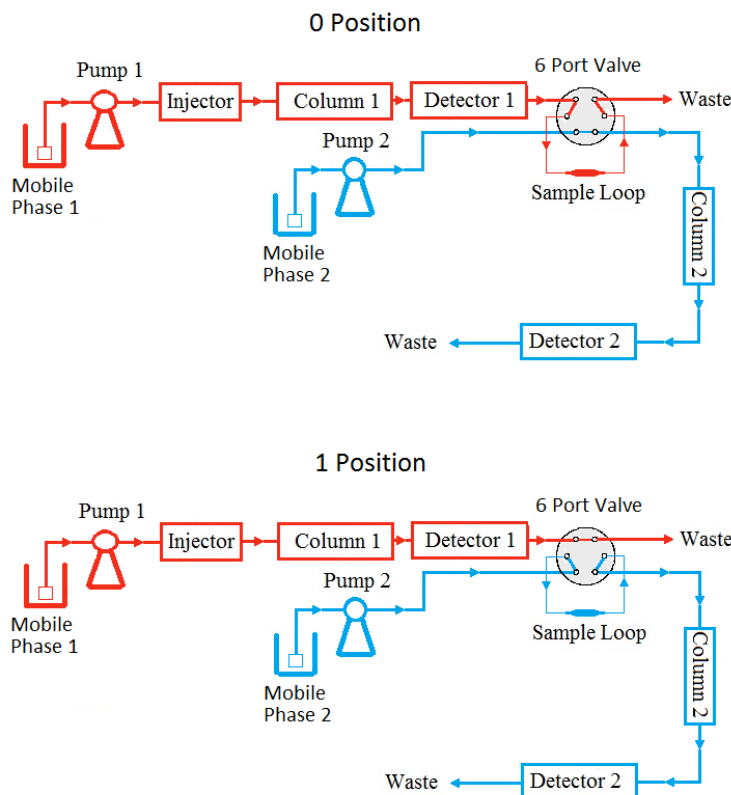

Fig. (2). The scheme of the online heart-cutting LC system for two valve positions.

Ultimately, during the analysis, changing the baseline and differentiation in pressure of the system as a result of switching the 6-port valve from position 0 to 1 were assayed.

2.4. Sample Preparation

5 mL venous blood samples collected from a healthy volunteer were transferred into test tubes and within 2 h from collection the samples were centrifuged for 15 min at 1400×g. The supernatant was placed into polypropylene tubes and stored at -20 °C until analysis.

0.1 mL linezolid solutions were added 0.5 mL of supernatant (serum), to obtain final concentration as 0.1-5 µg/mL. The spiked serum samples were vortexed for approximately 10 s and following that 1 mL of methanol was added and vortexed for 1 min. Each sample was filtered with 0.45 µm and 0.2 µm Nylon filter, respectively, and 80 µL filtrate were injected into the LC system.

2.5. Method Validation

The developed method was validated with respect to described parameters in guidelines such as accuracy, selectivity, recovery, precision, sensitivity, the calibration curve, reproducibility, carry over and stability of analyte [19].

The selectivity of the method was tested by both purity control of the linezolid peak using PDA detector and blank serum study.

Serum calibration standards were prepared at six levels by spiking 0.5 mL of human serum with the 0.5-20 µg/mL concentrations of linezolid. The spiked samples were prepared as previously described in *Sample Preparation* section and a portion of 80 µL was injected into the LC system. The calibration curves were generated by means of the least-square method using the analyte peak areas versus the corresponding concentrations of the linezolid (as µg/mL). The slope (a), intercept (b) and coefficients of determination (r^2), which were used to determine the concentration of linezolid in the serum samples, were obtained from the linear regression analysis of the calibration curves. The limit of quantitation (LOQ) was defined as the lowest concentration level giving a chromatographic response with acceptable coefficient of variation.

The absolute recovery was performed for three concentration level as 0.5, 10 and 20 µg/mL. For this purpose, dividing the mean peak area from spiked serum samples (extracted analyte) by mean peak area of standard solutions (unextracted analyte). The absolute recovery was calculated using the equation: absolute recovery = (response peaks of extracted/unextracted) × 100.

The precision and accuracy of the developed method were examined with regard to intra-day precision (repeatability) and inter-day precision (intermediate precision). For this purpose, spiked serum samples at three different concentration levels (0.5, 10 and 20 µg/mL) of linezolid were analyzed six times a day and six successive days in triplicate injections. The precision and the accuracy were calculated as relative standard deviation (RSD) and relative mean error (RME), respectively. Precision and accuracy values covering ± 15% of the actual range of experimental concentrations were considered acceptable. The prepared serum samples

with the procedure provided in the *Sample Preparation* section were injected into the LC system. Accuracy and precision were calculated from the data obtained and the results provided as mean ± SD, RSD and RME.

The stability of linezolid in serum samples was tested at 0.5 µg/mL (low) and 20 µg/mL (high) concentrations for following conditions; in the autosampler (+4 °C for 12 h), after three freeze-thaw cycles, on storage (-20 °C for 14 days).

2.6. Application of the Method

The validated method was used for the quantification of linezolid in human serum samples obtained from 43 years old a healthy volunteer's blood (77 kg, 178 cm height, Sagirli O., researcher of this study). After administering single oral dose of 600 mg of linezolid, venous blood samples were collected into tubes at 1.0-hour post dosing. The serum samples were obtained from venous blood as previously described in *Sample Preparation* section and the samples were stored at -20 °C until analysis.

3. RESULTS

3.1. Chromatographic System

For this purpose, various type of analytical columns were assayed especially for 2nd system like C₈, CN, C₁₈, PFPP, phenyl and biphenyl using different mobile phases. The chromatographic conditions obtained the isole and sharp linezolid peak was observed as follows;

Column (1st System): Restek Pinnacle DB BiPh (2.1 x 50 mm, 5 µm I.D.) at 30 °C

Mobile phase (1st System): Acetonitrile and 0.030 M o-phosphoric acid solution mixture (15:85) with 0.5 mL/min flow rate

Column (2nd System): Restek Allure PFPP (4.6 x 150 mm, 5 µm I.D.) at 30 °C

Mobile phase (2nd System): Acetonitrile and 0.03 M o-phosphoric acid solution mixture (25:75) with 1 mL/min flow rate

For both systems, 250 nm was selected as detection wavelength. Under this conditions, retention times were found as 1.9 and 7.6 min for the 1st and 2nd system, respectively (Fig. (3)).

3.1.1. Switching Time for Valve

For the selection of switching time, FCV-12A valve was rotated from position 0 to 1 at following time points, 2.0, 2.1, 2.2, 2.3, 2.4 and 2.5 minutes. Thus, 0.2 mL portion of 1st separation was sent to the 2nd system and peak areas obtained from 2nd chromatographic separation was investigated. Results indicated that peak areas were maximum when the valve rotation time was selected as 2.2 minute and this point was selected as valve switching time.

3.1.2. Loop Volume

The volume of the loop was investigated to enable the delivery of the analyte to the 2nd system. For this purpose, various volume of loops (0.1, 0.2, 0.5 and 1 mL) were tested according to peak areas and band broadening. The results

show that, the optimum analyte peaks were obtained with loop volume of 0.2 mL.

3.1.3. Differentiation on Pressure

Resulting from switching the 6-port valve, differences at baseline and changes the system pressure were investigated. As a result, it was found that the mixing the mobile phases at the transition between the systems did not have an impact on linezolid peak (Fig. (3B) and (3C)). System pressure was monitored when the 6-port valve was rotated. The pressure reached a stable level rapidly and stayed constant during the period of analysis.

3.2. Method Validation

The all analyte peaks were found as pure according to the peak purity index values obtained from PDA detector (mean peak purity index value was 0.9999981) and the blank serum studies.

The calibration curves were constructed using peak areas obtained versus the corresponding concentrations of the line-

zolid at the range of 0.5-20 µg/mL in human serum. The mean linear regression equation was calculated as $y = 4564x - 4602.7$ ($r^2 = 0.9993$) from calibration curves, where y represents the peak area of linezolid, x represents the serum concentrations of linezolid. The standard errors (SE) of the slope and intercept were found as 127.8 and 472.1, respectively. The coefficients of determination values ranged from 0.9982 to 0.9995, proving good linearity of the method. The LOQ measured with acceptable precision and accuracy under the described conditions for the developed method in serum was 75 ng/mL for which the RSD value was less than 20%.

Tree different concentration levels (0.5, 10 and 20 µg/mL) of linezolid were spiked at the blank human serum for absolute recovery study. As a result, absolute recovery of linezolid for serum samples was found as 91.43% (Table 1).

Results of precision studied within the same day analytical run and analytical runs performed in different days at 3 different concentrations of linezolid representing low, medium and high concentrations are provided in Table 2 and Table 3, respectively. RSD values were calculated to be in

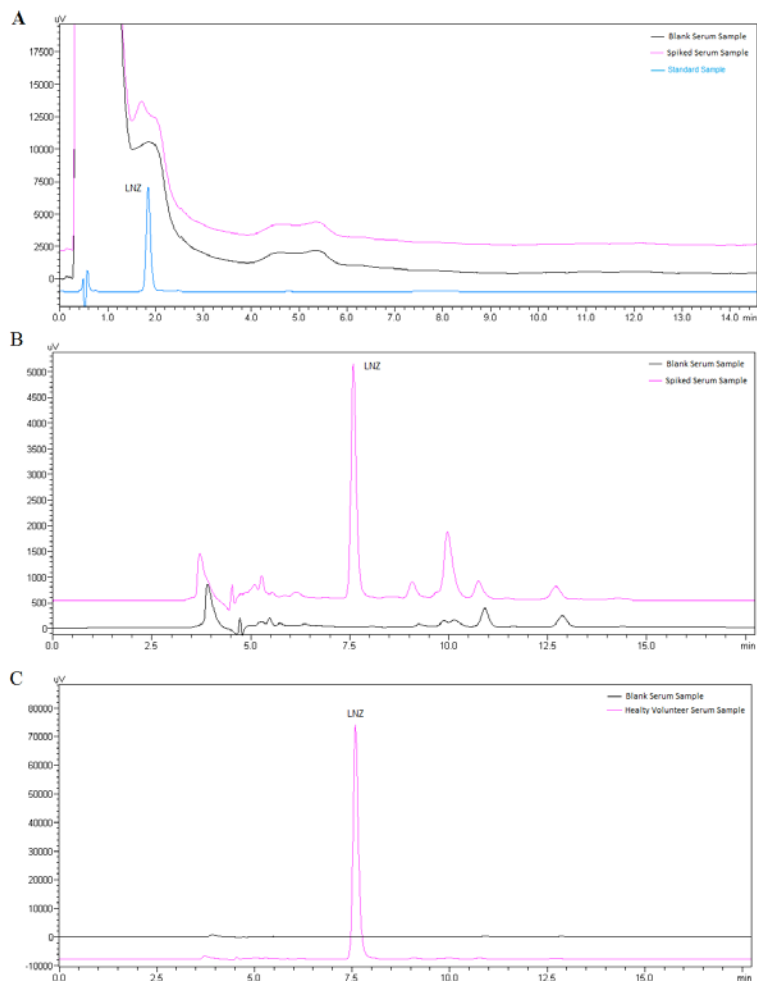

Fig. (3). (A) Chromatograms of the blank serum sample, serum sample spiked with linezolid (1.0 µg/mL) and standard linezolid solution (1.0 µg/mL) at the 1st system.

(B) Chromatograms of the blank serum sample and serum sample spiked with linezolid (1.0 µg/mL) at the 2nd system.

(C) Chromatograms of the blank serum sample and healthy volunteer serum sample (obtained from 1.0 h after oral administration of Zyvoxid) at the 2nd system.

Table 1. Extraction recovery of Linezolid from serum.

Added concentration ($\mu\text{g/mL}$)	Found Concentration ($\mu\text{g/mL}$) \pm SD	Recovery (%)	RSD (%)
0.5	0.45 \pm 0.012	90.33	2.59
10.0	9.21 \pm 0.129	92.05	1.40
20.0	18.38 \pm 0.308	91.91	1.68

Table 2. Intra-day precision values.

	Added Concentration ($\mu\text{g/mL}$)		
	0.5	10.0	20.0
Found Concentration ($\mu\text{g/mL}$)	0.478	9.73	19.90
	0.499	9.85	20.04
	0.485	9.97	19.75
	0.501	9.89	20.00
	0.507	9.98	20.12
	0.487	10.14	19.58
Mean	0.493	9.93	19.90
SD	0.011	0.139	0.201
RSD (%)	2.26	1.40	1.01
RME (%)	-1.43	-0.73	-0.51

Table 3. Inter-day precision values.

	Added Concentration ($\mu\text{g/mL}$)		
	0.5	10.0	20.0
Found Concentration ($\mu\text{g/mL}$)	0.495	9.76	19.77
	0.491	10.02	20.01
	0.462	9.98	19.92
	0.504	9.99	19.88
	0.510	9.62	20.12
	0.480	10.11	19.39
Mean	0.490	9.91	19.85
SD	0.0174	0.184	0.254
RSD (%)	3.54	1.86	1.28
RME (%)	-1.93	-0.87	-0.76

the interval of 1.01-2.26 for intraday precision and 1.28-3.54 for inter-day precision. RME values were calculated to be within the interval of 0.51-1.41 and 0.76-1.93 for intra- and inter-day assay, respectively. The findings of precision and accuracy assay met the acceptance criteria established in guidelines for bioanalytical studies. According to stability study findings, linezolid was found to be stable under tested conditions in the current study (maximum deviation was found to be 2.97%).

3.3. Application of the Method

The developed method was applied for the quantification of linezolid in human serum samples. The chromatographic graph resulting from analytical run of a biological sample of a healthy volunteer who has been given a single dose of Zyvoxid (having 600 mg of linezolid) film tablet is provided in Fig. (3C). Calculated linezolid concentration ($17.21 \pm 0.48 \mu\text{g/mL}$) based on analysis is consistent with literature data [20].

4. DISCUSSION

As mentioned above, various liquid chromatographic methods were referred for the quantification of linezolid in human biological fluids. Some of these methods including laboring extraction procedures like liquid-liquid extraction or solid phase extraction and special sample preparation techniques like microdialysis or high-cost instruments. The major advantage of the developed method over all reported methods is simplicity of sample cleanup procedure. The serum samples were mixed with methanol and filtered just before the analysis. The proposed method is sensitive and reliable and also having simplistic sample preparation with excellent separation technique without internal standard. The new heart-cutting LC system was designed based on a Shimadzu LC-20A model liquid chromatography system. Second separation was carried out via only one 6-port valve having 0.2 mL sample loop. Proposed heart-cutting approach enables automatic analysis through non complicated sample treatment procedure having a lower total cost and shorter total operation time compared to widely used analytical setup. Unlike the currently used classical 2D LC set up the developed approach needs shorter run time in the 1st system column and longer run time in the second column. The new method was validated current ICH Guidelines preferring optimized chromatographic conditions and 2D system parameters and used for the quantification of linezolid in serum samples obtained from a volunteer.

5. CONCLUSION

This is the first method for the quantification of linezolid in human serum by online heart-cutting LC in literature. Developed and validated method was successfully applied for the quantification of linezolid in serum samples from 600 mg single dose treatment of 43 years old healthy volunteer. Results demonstrated that the developed method is applicable for the quantification of linezolid in human serum for pharmacokinetic studies.

CONFLICT OF INTEREST

The authors confirm that this article content has no conflict of interest.

ACKNOWLEDGEMENTS

This research was supported by the Research Fund of Istanbul University with the Project No: 24466 and 41047.

DISCLOSURE

“Part of this article has been reproduced from the Chromatographia, February 2016, Volume 79, Issue 3, pp 137-144; DOI:10.1007/s10337-015-3013-9”.

REFERENCES

- Perry, C.M.; Jarvis, B. Linezolid: a review of its use in the management of serious gram-positive infections. *Drugs*, **2001**, *61*(4), 525-551.
- Welshman, I.R.; Sisson, T.A.; Jungbluth, G.L.; Stalker, D.J.; Hopkins, N.K. Linezolid: absolute bioavailability and the effect of food on oral bioavailability. *Biopharm. Drug Dispos.*, **2001**, *22*(3), 91-97
- Tobin, C.M.; Sunderland, J.; White, L.O.; MacGowan, A.P. A simple, isocratic high-performance liquid chromatography assay for linezolid in human serum. *J. Antimicrob. Chemother.*, **2001**, *48*(5), 605-608.
- Borner, K.; Borner, E.; Lode, H. Determination of linezolid in human serum and urine by high-performance liquid chromatography. *Int. J. Antimicrob. Agents.*, **2001**, *18*(3), 253-258.
- Buerger, C.; Joukhadar, C.; Muller, M.; Kloft, C. Development of a liquid chromatography method for the determination of linezolid and its application to *in vitro* and human microdialysis samples. *J. Chromatogr. B Analyt. Technol. Biomed. Life Sci.*, **2003**, *796*(1), 155-164.
- Boak, L.M.; Li, J.; Nation, R.L.; Rayner, C.R. High-performance liquid chromatographic method for simple and rapid determination of linezolid in human plasma. *Biomed. Chromatogr.*, **2006**, *20*(8), 782-786.
- Cavazos-Rocha, N.; Vera-Cabrera, L.; Welsh-Lozano, O.; Waksman-de-Torres, N.; de la Luz Salazar-Cavazos, M. Simultaneous determination and validation of antimicrobials in plasma and tissue of actinomycetoma by high-performance liquid chromatography with diode array and fluorescence detection. *J. Pharm. Biomed. Anal.*, **2007**, *43*(5), 1775-1781.
- Cattaneo, D.; Baldelli, S.; Conti, F.; Cozzi, V.; Clementi, E. Determination of linezolid in human plasma by high-performance liquid chromatography with ultraviolet detection. *Ther. Drug Monit.*, **2010**, *32*(4), 520-524.
- Zander, J.; Maier, B.; Zoller, M.; Teupser, D.; Vogeser, M. Quantification of linezolid in serum by LC-MS/MS using semi-automated sample preparation and isotope dilution internal standardization. *Clin. Chem. Lab. Med.*, **2014**, *52*(3), 381-389.
- Hara, S.; Uchiyama, M.; Yoshinari, M.; Matsumoto, T.; Jimi, S.; Togawa, A.; Takata, T.; Takamatsu, Y. A simple high-performance liquid chromatography for the determination of linezolid in human plasma and saliva. *Biomed. Chromatogr.*, **2015**, *29*(9), 1428-31
- Ehrlich, M.; Trittler, R.; Daschner, F.D.; Kümmerer, K. A new and rapid method for monitoring the new oxazolidinone antibiotic linezolid in serum and urine by high performance liquid chromatography-integrated sample preparation. *J. Chromatogr. B Biomed. Sci. Appl.*, **2001**, *755*(1-2), 373-377.
- Peng, G.W.; Stryd, R.P.; Murata, S.; Igarashi, M.; Chiba, K.; Aoyama, H.; Aoyama, M.; Zenki, T.; Ozawa, N. Determination of linezolid in plasma by reversed-phase high-performance liquid chromatography. *J. Pharm. Biomed. Anal.*, **1999**, *20*(1-2), 65-73.
- Toutain, J.; Boselli, E.; Djabarouti, S.; Allaouchiche, B.; Xuereb, F.; Bernadou, J.M.; Ba, B.; Saux, M.C.; Breilh, D. Determination of linezolid in plasma and bronchoalveolar lavage by high-performance liquid chromatography with ultraviolet detection using a fully automated extraction method. *J. Chromatogr. B Analyt. Technol. Biomed. Life Sci.*, **2004**, *813*(1-2), 145-150.
- Vu, D.H.; Bolhuis, M.S.; Koster, R.A.; Greijdanus, B.; de Lange, W.C.; van Altena, R.; Brouwers, J.R.; Uges, D.R.; Alffenaar, J.W. Dried blood spot analysis for therapeutic drug monitoring of linezolid in patients with multidrug-resistant tuberculosis. *Antimicrob. Agents Chemother.* **2012**, *56*(11), 5758-5763.
- Shalliker, R.A.; Gray, M.J. Concepts and practice of multidimensional high-performance liquid chromatography. *Adv. Chromatogr.*, **2006**, *44*, 177-236.
- Regnier, F.; Amini, A.; Chakraborty, A.; Geng, M.; Ji, J.; Riggs, L.; Sioma, C.; Wang, S.; Zhang, X. Multidimensional chromatography and the signature peptide approach to proteomics. *LC-GC N Am.*, **2001**, *19*(2), 200.
- Dixon, S.P.; Pitfield, I.D.; Perrett, D. Comprehensive multidimensional liquid chromatographic separation in biomedical and pharmaceutical analysis: a review. *Biomed. Chromatogr.*, **2006**, *20*(6-7), 508-529.
- Stoll, D.R.; Li, X.; Wang, X.; Carr, P.W.; Porter, S.E.G.; Rutan, S.C. High Temperature, Fast Two-Dimensional Liquid Chromatography. *J. Chromatogr. A*, **2007**, *1168*(1-2): 3-43.
- Food and Drug Administration. FDA Guidance for Industry: Bioanalytical Method Validation. Rockville, MD: US Department of Health and Human Services, Food and Drug Administration, Center for Drug Evaluation and Research. <http://www.fda.gov/downloads/drugs/guidancecomplianceregulatoryinformation/guidances/ucm368107.pdf> (Accessed September 2013).
- Gee, T.; Ellis, R.; Marshall, G.; Andrews, J.; Ashby, J.; Wise, R. Pharmacokinetics and tissue penetration of linezolid following multiple oral doses. *Antimicrob. Agents Chemother.*, **2001**, *45*(6), 1843-1846.